

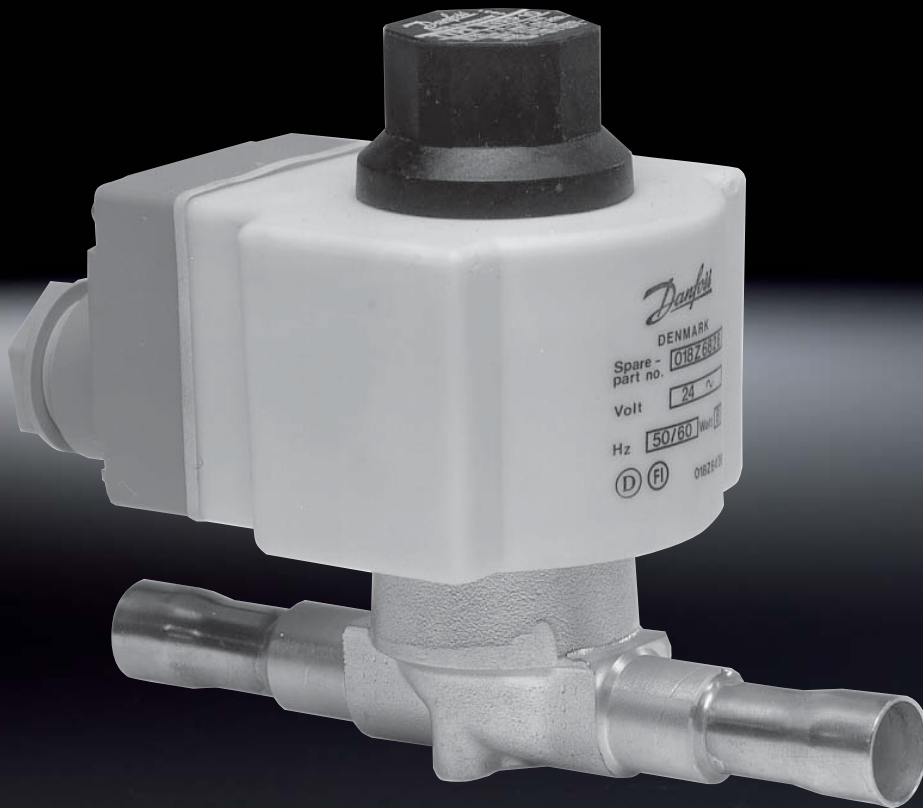

Technical brochure

# Capacity regulation with pulse solenoid valve EVRP 10



**Introduction**



Danfoss has developed a pulsating solenoid valve, EVRP 10, for use in applications where an extremely accurate regulation of media temperature is required.

Pulse solenoid valve EVRP 10 is used as a capacity regulator to adapt compressor capacity to the actual evaporator load.

EVRP 10 must be installed in a bypass between the high and low pressure sides of the refrigeration system. It is specially designed for hot gas injection between evaporator and expansion valve.

**Application**

- Container refrigeration systems
- Ice cream production
- Air conditioning plant

**Function**

Capacity regulation is controlled by a signal from a temperature sensor located in the cooled medium, for instance air. The signal is converted by a control unit into a pulse modulated signal for the EVRP pulse solenoid valve.

This form of regulation is very stable. Variations in the temperature of refrigerated items can be held within  $\pm 0.25^{\circ}\text{C}$ .

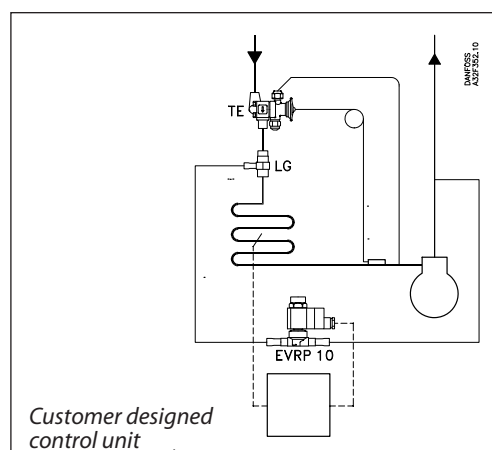

**Ordering**

*Separate valve body*

Type	Connection	Code no.
EVRP 10	1/2 in. solder ODF	<b>032F3298</b>

*Coils for EVRP 10*

Voltage	Frequency	Connection	Power consumption	Code no.
24 V a.c.	50/60 Hz	Terminal box	8 W	<b>018Z6826</b>
20 $\pm$ 4 V d.c.		Terminal box	14 W	<b>018Z6875</b>
24 $\pm$ 4 V d.c.		Terminal box	14 W	<b>018Z6964</b>

**Technical data**

*Valve body*

Refrigerants	R 134a, R 502
$k_v$ value	1.5 m <sup>3</sup> /h
Min. opening differential pressure	0.05 bar
Max. opening differential pressure	21 bar
Max. working pressure, PB	42 bar
Media temperature	-60 - +120°C
Mounting condition	Armature vertically upwards $\pm 30^{\circ}$
Max. operating cycles	10 per minute
Life in no. of operating cycles	Min. $5 \times 10^6$

*Coils*

Type	018Z6826	018Z6875	018Z6964
Rated supply voltage	24 V a.c. -10/+25%	20 $\pm$ 4 V d.c.	24 $\pm$ 4 V d.c.
Rated power consumption	8 W	14 W	14 W
Ambient temperature	-40 - +80°C	-40 - +50°C	-40 - +50°C
Enclosure	IP 67	IP 67	IP 67
Screws	18/8 stainless steel	18/8 stainless steel	Zn-chromated
Coil colour	White	Black	Blue

**Hot gas replacement capacity**

Capacities are given for 100% opening of EVRP and are composed of the EVRP hot gas capacity + the extra capacity yielded by the thermostatic expansion valve to maintain constant superheat across the evaporator.

Evaporating temperature t <sub>e</sub> °C	Hot gas replacement capacity Q kW at condensing temperature t <sub>c</sub> °C				
	+20	+30	+40	+50	+60
+10	12.2	16.5	20.3	24.5	28.7
0	13.0	16.6	20.5	24.6	28.9
-10	13.1	16.7	20.6	24.9	29.2
-20	13.2	16.8	20.8	25.2	29.6
-30	13.4	17.0	21.1	25.5	30.2
+10	16.1	21.4	25.0	28.6	31.8
0	17.9	21.6	25.2	28.9	32.1
-10	18.1	21.7	25.5	29.2	32.6
-20	18.2	21.9	25.8	29.6	33.1
-30	18.4	22.2	26.2	30.1	33.7

Subcooling = 4 K. Superheat = 0 K.

The evaporator load is given by the actual application and the limits set when sizing the system. The compressor capacity can be found from data supplied. The difference between compressor capacity and evaporator output at any given time is the required hotgas replacement capacity.

*Example:*

The temperature of refrigerated items in an R 134a container refrigeration system must be precisely 8°C.

According to the specification, the compressor capacity at an evaporating temperature of 0°C and a condensing temperature of 40°C is 70 kW. The evaporator output needed to maintain the temperature of the items in the container at 8°C is calculated as 58 kW.

To obtain balance in the refrigeration system, 70 – 58 = 12 kW must be applied to the low-pressure side via EVRP 10.

At an evaporating temperature of 0°C and a condensing temperature of 40°C, EVRP gives 20.5 kW at 100% opening (see capacity table above).

The 12 kW therefore corresponds to a degree of opening of EVRP 10 to:

$$\frac{12 \times 100}{20.5} = 59\%$$

If changes occur in the ambient temperature of the required evaporator output, etc. the degree of opening of EVRP 10 is constantly changed via the control unit to maintain the temperature of refrigerated items within the range 8°C ±0.25°C.

Dimensions and weight

Separate valve body for EVRP 10

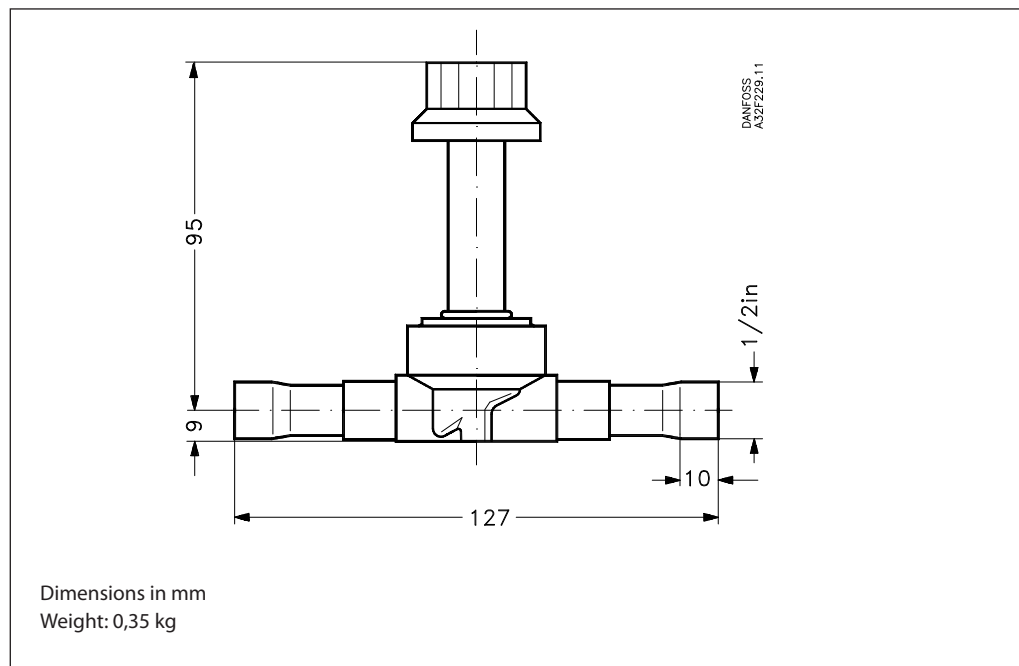

Coils for EVRP 10

